

WIRING INSTRUCTIONS 110VAC 3 WIRE MOTOR USING A 3 WAY SWITCH

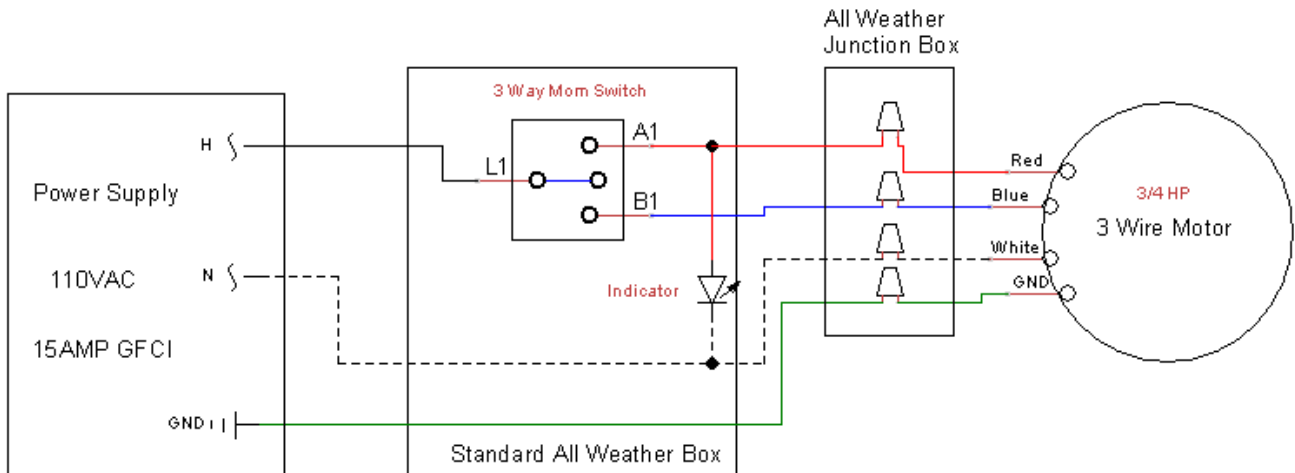

Installation Notes:

- * The control switch is mounted in a standard depth single gang all weather box.
- * Motor connections are made in an all-weather box mounted as high as possible in the cover box.
- * The control switch must be mounted in a location where 100% of the pool surface is visible.
- * The **HOT** (black) wire from the power supply connects to the L1 terminal on the switch.
- * The **NEUTRAL** (white) wire from the power supply connects to the indicator light and also passes through to be connected at the motor conduit white wire.
- * The remaining wire on the indicator light connects to a directional terminal on the switch (A1 or A2).
- * The Red and Blue wires from the motor connect to the directional terminals on the switch. (A1 and A2) The red and blue wires may be switched with each other to change the motor direction.
- * The motor requires 8 amps and all wiring from the power supply to the motor must be sized accordingly.
- * Use a 15amp GFCI breaker at the panel.

Troubleshooting Tips:

- * If the indicator light does not come on in either switch position, check the power supply for 110v.
- * If the indicator light comes on in one direction but not the other, the problem is probably a connection either at the switch or in the junction box in the cover box.
- * If the indicator light comes on in both directions but the motor does not run at all, check the neutral wire and it's connections.

THEN CHECK THE FOLLOWING

- * Disconnect wires from the switch and test for continuity, you should have continuity between L1 and A1 when you toggle the switch in one direction and between L1 and A2 in the other direction. (Do not attempt to run this test with wires connected to the switch, you will get false readings.)
- * Using a test cord, disconnect wires in the all weather box and connect the neutral wire to the white motor wire and connect the hot wire to the red motor wire. The motor should run. Then switch the hot wire over to the blue motor wire. The motor should run in the other direction. If the motor runs in both directions using this method, the trouble is in the components or wiring leading up to that point in the system. If the motor still does not run properly, you may need to investigate the capacitor inside the control box mounted on top of the motor.

